



US 20050212414A1

(19) **United States**

(12) **Patent Application Publication**

Matsusue et al.

(10) **Pub. No.: US 2005/0212414 A1**

(43) **Pub. Date: Sep. 29, 2005**

(54) **LIGHT EMITTING DISPLAY APPARATUS WITH SLIGHT COLOR SHIFTING**

Publication Classification

(51) **Int. Cl.⁷ H01J 1/62; H01J 63/04**

(52) **U.S. Cl. 313/504**

(76) Inventors: **Noriyuki Matsusue, Osaka (JP);
Kunimoto Ninomiya, Osaka (JP)**

(57) **ABSTRACT**

Correspondence Address:
**MCDERMOTT WILL & EMERY LLP
600 13TH STREET, N.W.
WASHINGTON, DC 20005-3096 (US)**

A light emitting display apparatus that achieves color display by using white light as a light source includes a plurality of organic light emitting devices each of which includes an organic light emitting layer that emits the white light. The organic light emitting device is configured so that a resonant wavelength in a thickness direction of the organic light emitting layer is positioned in the blue region of the spectrum. The light emitting display apparatus further includes a plurality of wavelength selection units each of which is provided on a path of the emission of the white light. The wavelength selection unit transmits light of a particular wavelength included in the white light.

(21) Appl. No.: **11/079,528**

(22) Filed: **Mar. 15, 2005**

(30) **Foreign Application Priority Data**

Mar. 25, 2004 (JP) JP2004-89131

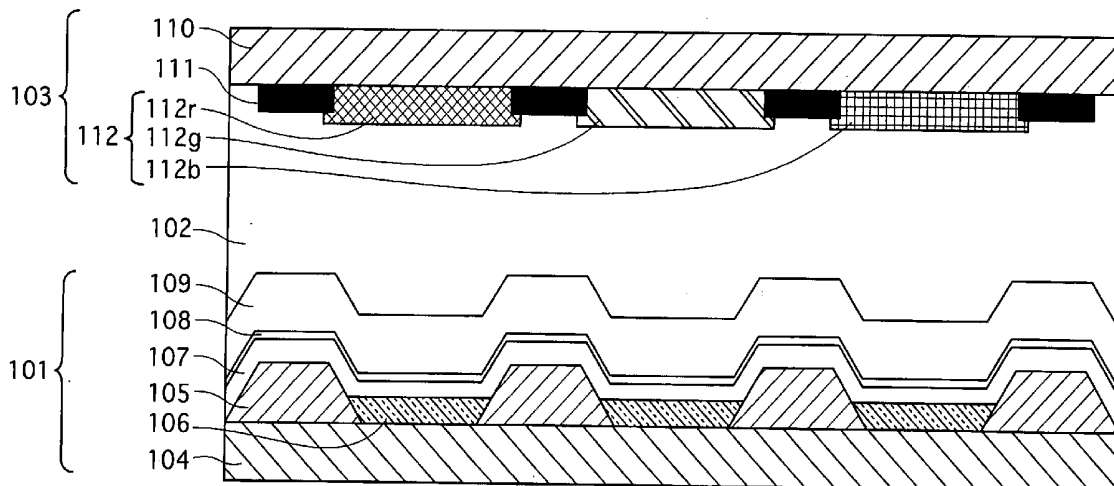

100

FIG. 1

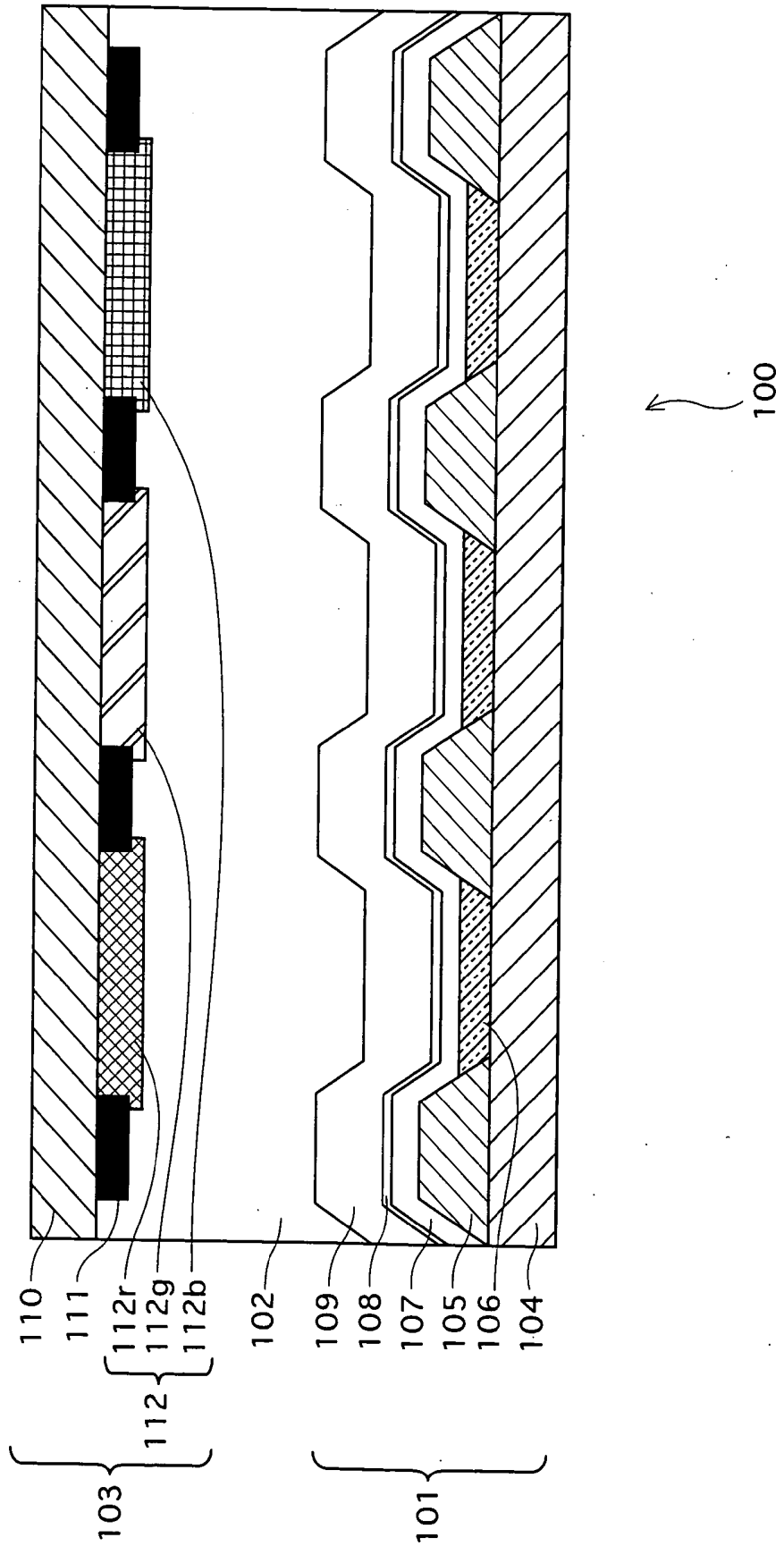

FIG.2

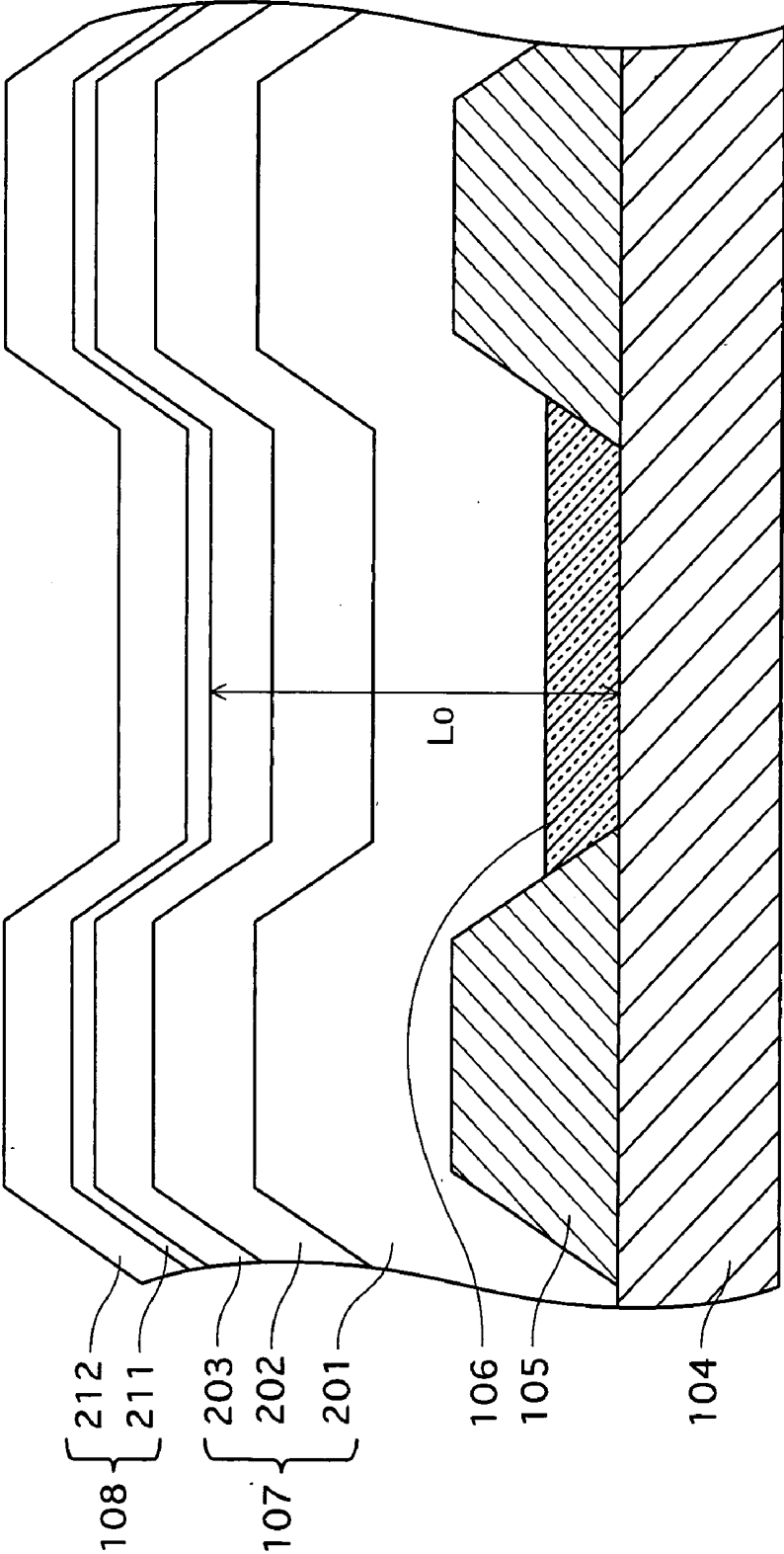

FIG.3

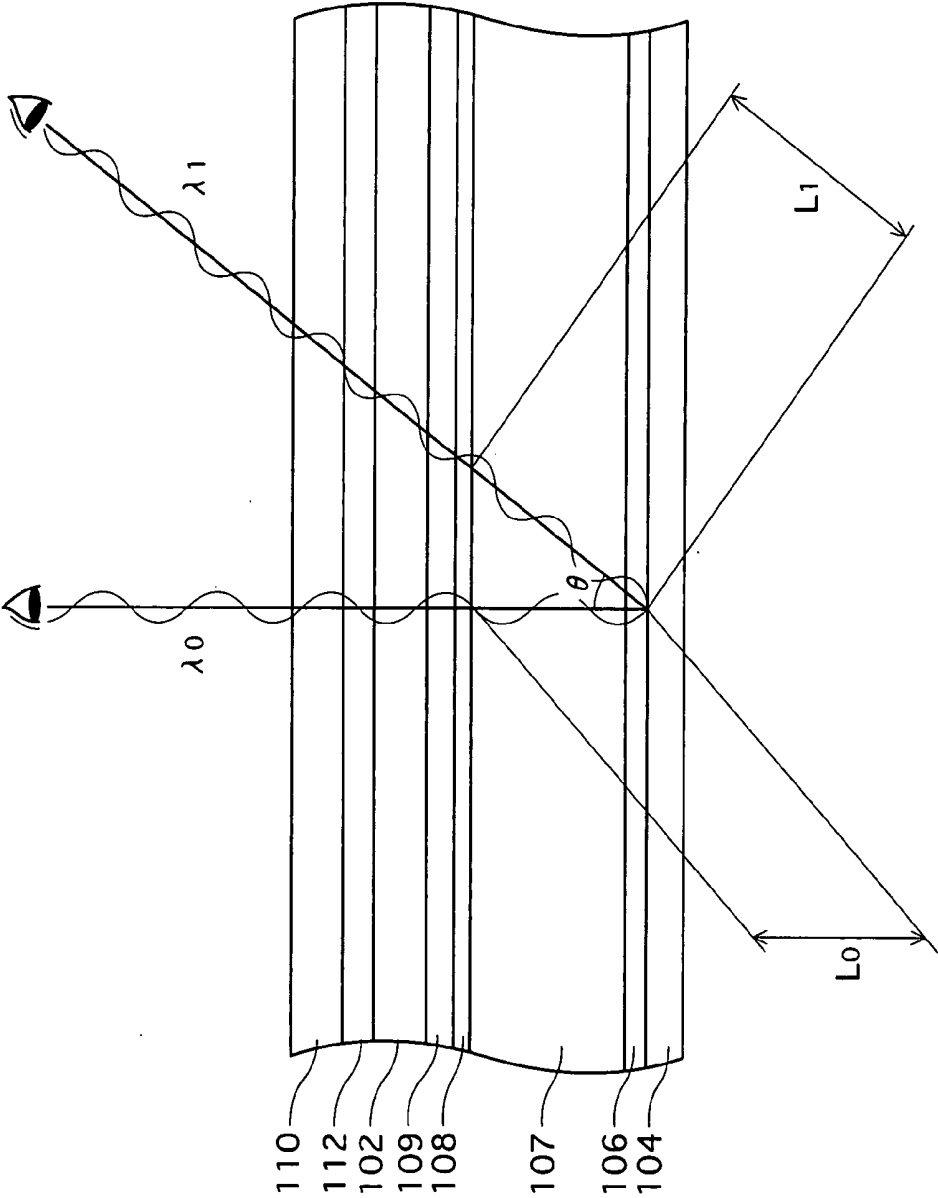

FIG. 4C

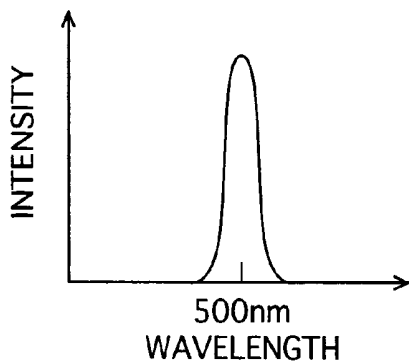

FIG. 4F

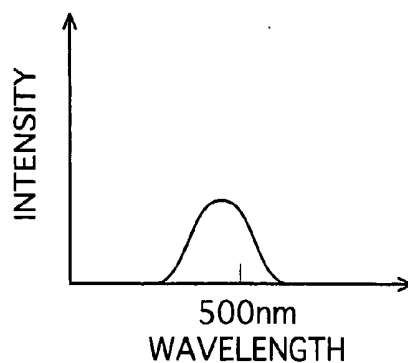

FIG. 4B

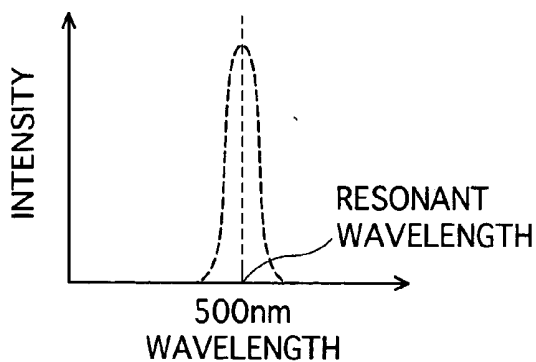

FIG. 4E

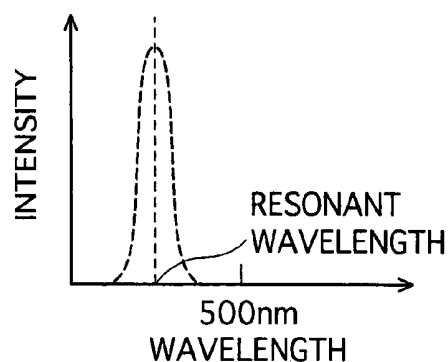

FIG. 4A

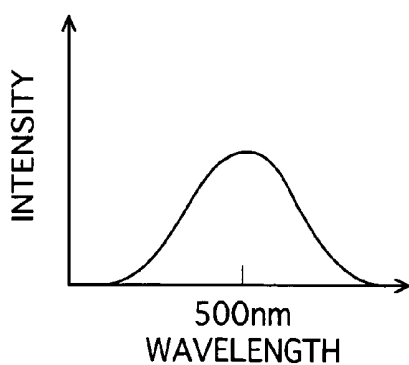

FIG. 4D

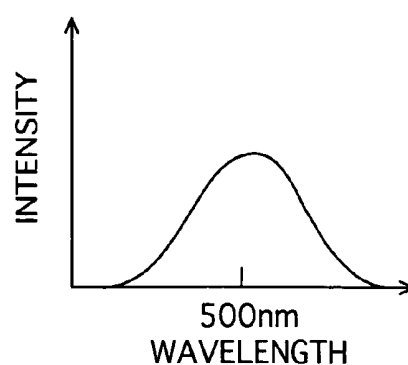

FIG. 5A

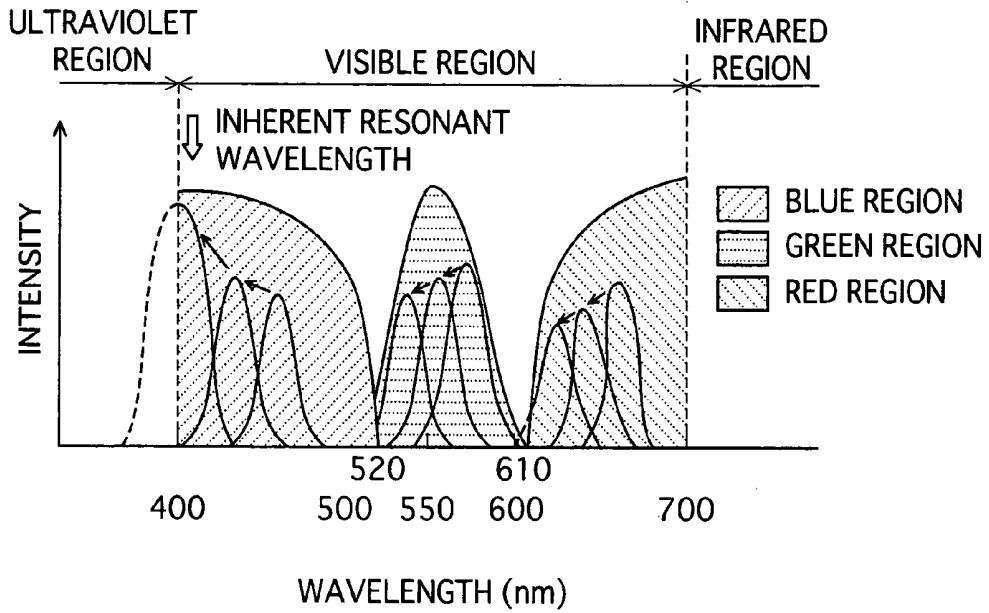

FIG. 5B

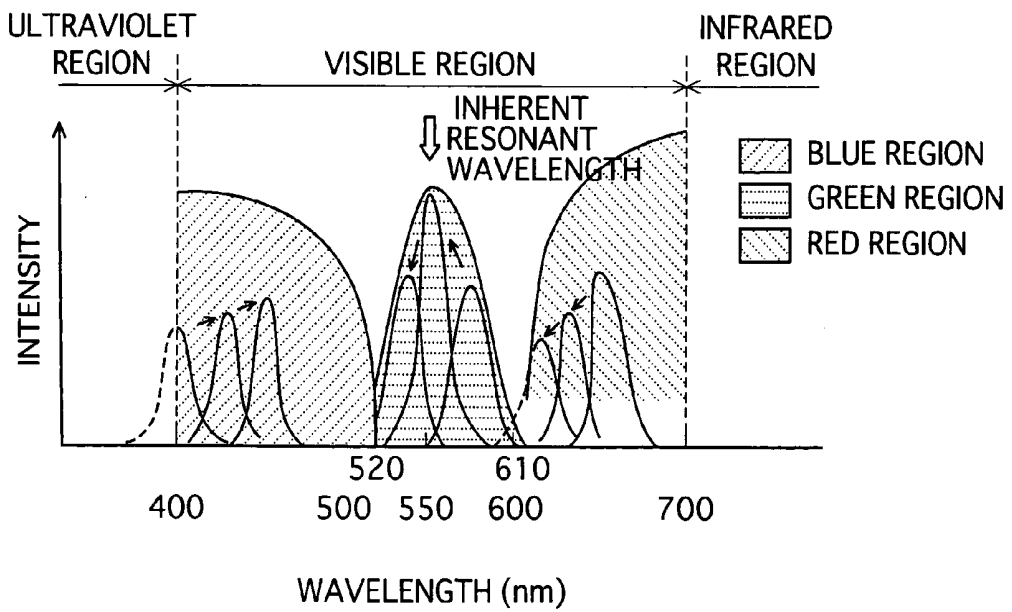
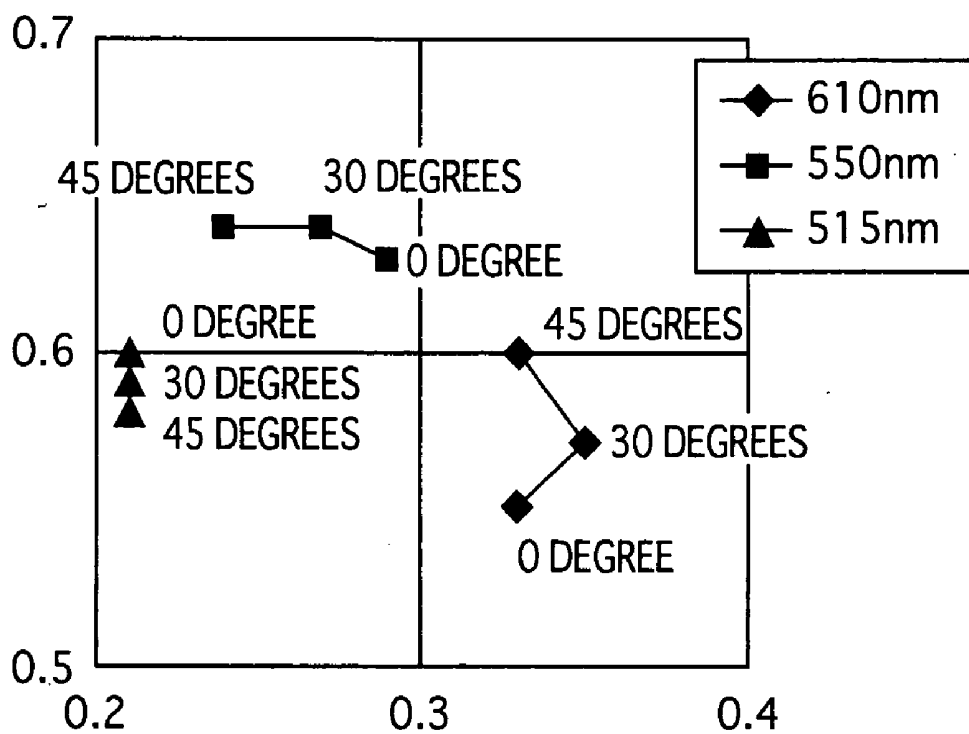
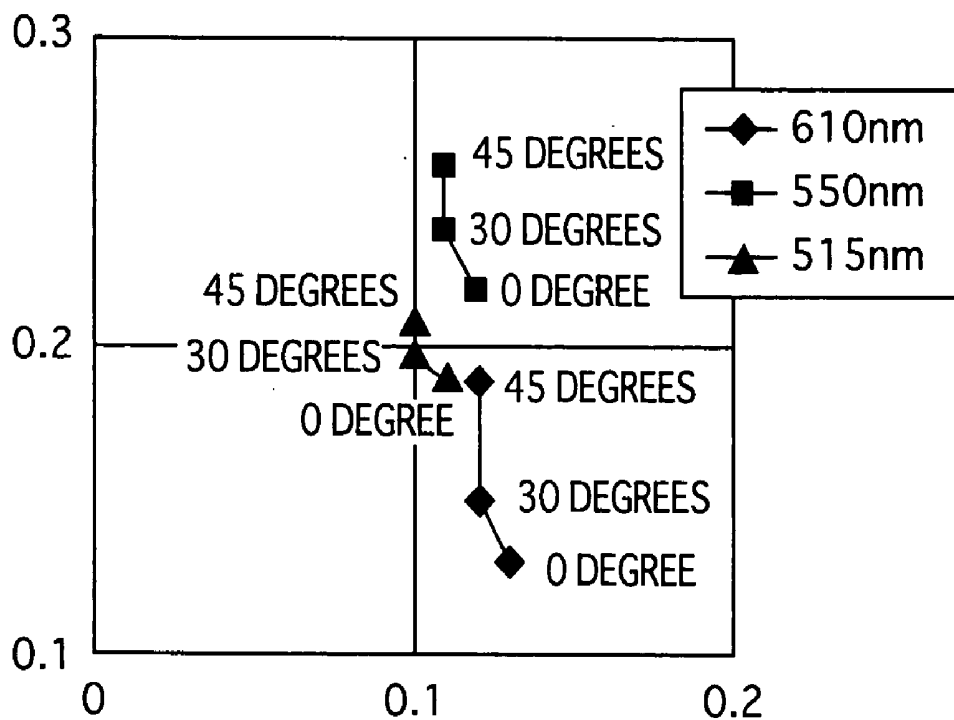

FIG.6



CHROMATICITY DIAGRAM

FIG.7



CHROMATICITY DIAGRAM

FIG.8

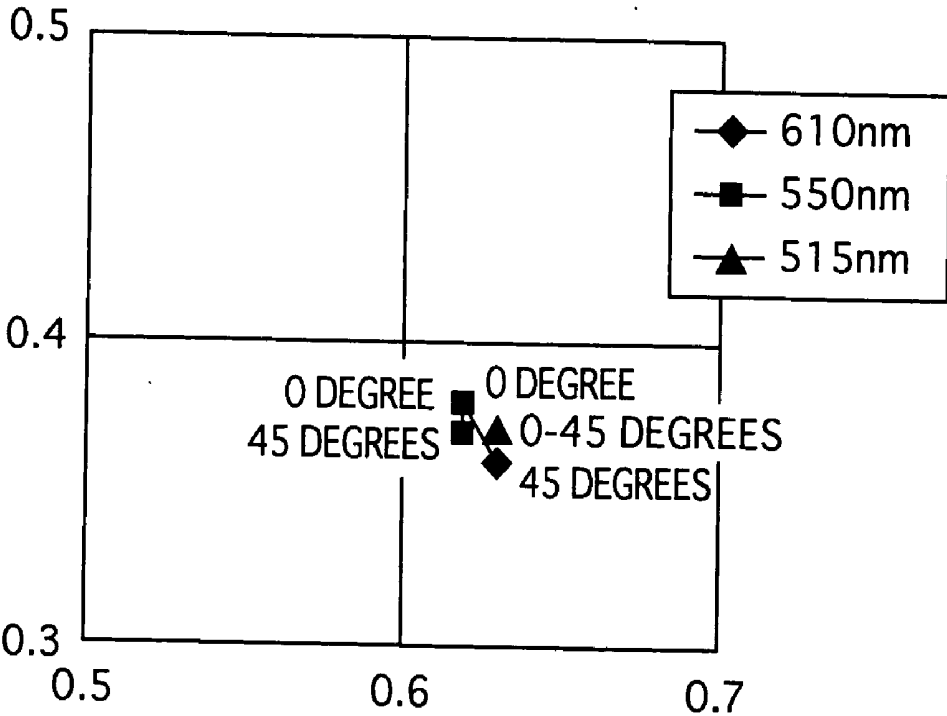

CHROMATICITY DIAGRAM

LIGHT EMITTING DISPLAY APPARATUS WITH SLIGHT COLOR SHIFTING

BACKGROUND OF THE INVENTION

[0001] (1) Field of the Invention

[0002] The present invention relates to a light emitting display apparatus of a top emission type, particularly to a technique to enhance visibility.

[0003] (2) Description of the Prior Art

[0004] In recent years, light emitting display apparatuses in which self-luminous devices are driven using thin-film transistors (hereinafter referred to as TFTs) attract attention, because of their ability to realize display apparatuses having high efficiency, high definition, low power consumption, and high-speed response. One type of such light emitting display apparatuses is top-emission organic electroluminescence panels (hereinafter referred to as organic EL panels), and vigorous researches are conducted on top-emission organic EL panels. In a top-emission organic EL panel, organic light emitting devices formed on a TFT substrate emit light. This light is emitted in a direction opposite to a direction through the substrate in which TFTs, wirings and the like are formed. As a result, the light is extracted from a "top" side of the panel highly efficiently.

[0005] This top-emission organic EL panel achieves color display in the following manner, as disclosed in Japanese patent application publication No. 2003-257622, for example. The organic light emitting devices emit white light to the "top" side. Color filters, which are provided in the direction of the light emission, selectively transmit and separate three primary colors composing the white light. Such a top-emission organic EL panel has advantages including a high luminous efficiency and a bright display on a screen, in addition to distinct features of general organic EL panels such as a thin panel and a wide viewing angle.

[0006] However, the top-emission organic EL panel has the following drawback. In the top-emission organic EL panel, an organic light emitting layer, which actually emits the light, is sandwiched between highly reflective layers. Therefore, the emitted light resonates, so that light of a particular wavelength is enhanced. Which is to say, a resonant structure is formed. Here, the resonant wavelength is different depending on an angle with respect to a direction perpendicular to a display unit of the panel. Accordingly, the color of the light emitted from the organic light emitting layer appears different for a user between when the user watches the display unit in the direction perpendicular to the display unit and when the user watches the display unit in a direction having an angle with respect to the perpendicular direction. This drawback is called color shifting.

[0007] In more detail, when the user watches the display unit of the light emitting display apparatus having a resonant structure in the direction having an angle with respect to the direction perpendicular to the display unit, a resonant wavelength in the direction in which the user watches the display unit is shifted to a shorter wavelength, in comparison with a resonant wavelength in the direction perpendicular to the display unit. In accordance with this change, a wavelength of light received by the user (hereinafter referred to as received light) is shifted to a shorter wavelength, and an intensity of the received light also changes. These changes cause color shifting.

SUMMARY OF THE INVENTION

[0008] In view of the above problem, an object of the present invention is to provide a top-emission light emitting display apparatus which hardly causes color shifting even when a user watches a display unit in a direction having an angle with respect to a direction perpendicular to the display unit.

[0009] The above object can be achieved by a light emitting display apparatus that achieves color display by using white light as a light source. The light emitting display apparatus includes a plurality of organic light emitting devices each of which includes an organic light emitting layer that emits the white light. The organic light emitting device is configured so that a resonant wavelength in a thickness direction of the organic light emitting layer is positioned in the blue region of the spectrum. The light emitting display apparatus further includes a plurality of wavelength selection units each of which is provided on a path of the emission of the white light. The wavelength selection unit transmits light of a particular wavelength included in the white light.

[0010] According to this construction, the resonant wavelength in the thickness direction of the organic light emitting layer, i.e. an inherent resonant wavelength, is positioned in the blue region of the spectrum. Suppose a user watches a display unit in a direction having an angle with respect to the direction perpendicular to the display unit. A resonant wavelength in the direction in which the user watches the display unit is shifted to a shorter wavelength, when compared with the inherent resonant wavelength. In accordance with this change, the intensities of green light and red light included in light received by the user are reduced, but the reduction is limited. This is because the wavelengths of the green light and red light in the received light are positioned far away from the inherent resonant wavelength. As a result, the shift of the wavelengths and the reduction in the intensities are limited, as for the green and red light in the received light.

[0011] Since the resonant wavelength in the direction in which the user watches the display unit is shifted to a shorter wavelength, the wavelength of blue light included in the received light is shifted to a shorter wavelength. In addition, the intensity of the blue light peaks at a shorter wavelength, and is raised.

[0012] Here, while the intensity of the blue light in the received light becomes higher at a shorter wavelength, part of the blue light is included in the ultraviolet region which indicates less visibility. For this reason, the change in the intensity of the blue light in the received light appears to be limited for the user.

[0013] Thus, even when the user watches the display unit in the direction having an angle with respect to the direction perpendicular to the display unit, the change in luminance of the blue, green and red light in the received light is moderate. This causes only slight color shifting.

[0014] Here, the blue region of the spectrum may indicate a wavelength range of 400 nm to 520 nm, inclusive.

[0015] According to this construction, when the angle increases, the height of the intensity peak of the blue light in the received light increases, but the intensity-wavelength distribution of the blue light is partly included in the

ultraviolet region. Thus, the amount of the visible blue light is lowered. As a consequence, the increase in the intensity of the blue light appears to be limited for the user.

[0016] Here, the resonant wavelength preferably fall within a range of 400 nm to 450 nm, inclusive.

[0017] According to this construction, the inherent resonant wavelength is set at a shorter wavelength, within the blue region. Therefore, the intensity-wavelength distribution of the blue light is easy to be included in the ultraviolet region, in accordance with the increase in the angle. This makes it easier to alleviate the increase in the intensity peak of the blue light, which is caused by the increase in the angle. As a result, color shifting is further limited.

[0018] Here, the wavelength selection unit is a color filter that transmits light of a corresponding one of three primary colors.

[0019] According to this construction, color shifting, which is caused by the increase in the angle, is limited in a normal light emitting display apparatus that achieves color display in such a manner that three primary colors of light mix, thereby emitting white light.

[0020] Here, at least one of a thickness of the organic light emitting layer, a refractive index of the organic light emitting layer, and a phase shift ϕ of the organic light emitting layer is adjusted so that the resonant wavelength in the thickness direction of the organic light emitting layer is positioned in the blue region of the spectrum.

[0021] According to this construction, the inherent resonant wavelength in the thickness direction of the organic light emitting layer is positioned in the blue region of the spectrum.

BRIEF DESCRIPTION OF THE DRAWINGS

[0022] These and other objects, advantages, and features of the invention will become apparent from the following description thereof taken in conjunction with the accompanying drawings, which illustrate a specific embodiment of the invention. In the drawings:

[0023] FIG. 1 is a schematic cross-sectional view illustrating an organic EL panel relating to an embodiment of the present invention;

[0024] FIG. 2 is a cross-sectional view illustrating, in detail, an organic layer and a cathode electrode relating to the embodiment of the present invention;

[0025] FIG. 3 illustrates a relation between an angle of an optical path and a resonant wavelength of light on the optical path;

[0026] FIG. 4 illustrates a relation among a light source wavelength, a light source intensity, a resonant wavelength, an output wavelength, and an output intensity;

[0027] FIG. 5 illustrates an output wavelength and an output intensity of light of each of three primary colors, when an angle of a direction in which a user watches a display unit increases with respect to a direction perpendicular to the display unit;

[0028] FIG. 6 shows positions, on a chromaticity diagram, of white light that is emitted from an organic layer and received by a user after having passed through a green color

filter, in the embodiment of the present invention, where the positions are observed based on simulations by varying an inherent resonant wavelength and the angle of direction in which the user watches the display unit with respect to the direction perpendicular to the display unit;

[0029] FIG. 7 shows positions, on a chromaticity diagram, of white light that is emitted from an organic layer and received by a user after having passed through a blue color filter, in the embodiment of the present invention, where the positions are observed based on simulations by varying an inherent resonant wavelength and the angle of direction in which the user watches the display unit with respect to the direction perpendicular to the display unit; and

[0030] FIG. 8 shows positions, on a chromaticity diagram, of white light that is emitted from an organic layer and received by a user after having passed through a red color filter, in the embodiment of the present invention, where the positions are observed based on simulations by varying an inherent resonant wavelength and the angle of direction in which the user watches the display unit with respect to the direction perpendicular to the display unit.

DESCRIPTION OF THE PREFERRED EMBODIMENT

[0031] <Construction>

[0032] FIG. 1 is a schematic cross-sectional view illustrating an organic EL panel, which is an example of a top-emission light emitting display apparatus, relating to an embodiment of the present invention.

[0033] An organic EL panel 100 relating to the embodiment of the present invention is formed in such a manner that self-luminous organic light emitting devices 101 and a color filter substrate 103 are opposed each other with a sealing layer 102 therebetween, as shown in FIG. 1. The color filter substrate 103 includes a plurality of color filter groups 112.

[0034] The color filter substrate 103 is formed in such a manner that the plurality of color filter groups 112 are disposed on a surface of a transparent substrate 110.

[0035] The transparent substrate 110 is made of glass, and has a thickness of approximately 0.5 mm to 1.0 mm. Alternatively, the transparent substrate 110 may be a plastic film.

[0036] The color filter groups 112 each include color filters 112r, 112g, and 112b, each of which transmits light of a corresponding one of three primary colors. The color filters 112r, 112g and 112b have a thickness of approximately no less than 1 μm but no more than 10 μm . In addition, black matrices 111 are provided between adjacent color filters.

[0037] Here, the color filters 112r, 112g and 112b may be formed in stripes, or in a matrix so that each color filter corresponds to a subpixel of a pixel.

[0038] The black matrices 111 are each a black film having a thickness of 1 μm to 6 μm . The black matrices 111 are provided to prevent light from leaking into adjacent subpixels, so that intended colors are precisely expressed.

[0039] The sealing layer 102 fills an internal space between the color filter substrate 103 and the organic light emitting devices 101. The sealing layer 102 thus limits

interfusion of oxygen, moisture and the like from outside. Also, the sealing layer **102** reduces reflection of light at an interface of the organic light emitting devices **101**, thereby transmitting light emitted from the organic light emitting devices **101** to the color filter groups **112** efficiently.

[0040] The sealing layer **102** is made of a material which transmits visible light, and has a refractive index of 1.3 to 2.5. For example, the sealing layer **102** can be made of an organic material such as transparent silicone rubber, transparent silicone gel, an epoxy resin, and an acryl resin.

[0041] The organic light emitting devices **101** are formed in the following manner. A plurality of TFTs (not illustrated in **FIG. 1**), which are covered with a planarized insulating film (not illustrated in **FIG. 1**), are provided on one of the main surfaces of a TFT substrate **104**. An insulation layer **105** is formed like a lattice, so as to surround each of the TFTs. A film-like anode **106** is formed in each area surrounded by the insulation layer **105**. An organic layer **107** including a light emitting layer, a cathode **108** and a protection layer **109** are formed in this order so as to cover the TFT substrate **104**, the insulation layer **105**, and the anode **106**.

[0042] The anode **106** is made of a material with a high work function in order to perform hole injection efficiently. Specifically speaking, the anode **106** includes a transparent conductive metal oxide layer made of ITO, IZO or the like. It is preferable to form a highly reflective metal layer under the metal oxide layer. The metal layer is made of, for example, chrome, silver, platinum, or an alloy including any of chrome, silver and platinum.

[0043] If the metal layer is formed, an interface between the metal layer and the metal oxide layer is a first reflective surface forming a resonant structure.

[0044] If the metal layer is not formed, an interface between the anode **106** and the TFT substrate **104** is the first reflective surface forming the resonant structure. This is because the TFT substrate **104** in contact with the anode **106** reflects light to a certain degree.

[0045] In the following description, the metal layer is assumed not to be provided.

[0046] As shown in **FIG. 2**, the cathode **108** has a two-layer structure made up by a semi-transparent electrode **211** and a transparent electrode **212**.

[0047] The transparent electrode **212** is formed on the semi-transparent electrode **211**. The transparent electrode **212** is made of translucent metal oxide such as ITO and IZO.

[0048] The semi-transparent electrode **211** is formed on the organic layer **107**. The semi-transparent electrode **211** partly transmits light from the organic layer **107**, and partly reflects the light.

[0049] The semi-transparent electrode **211** is formed by a thin metal film or the like having a thickness of 200 angstroms or less, and having a low work function. To be specific, the semi-transparent electrode **211** is made of, for example, metal such as aluminum, calcium, magnesium, silver, gold, an alloy of lithium or the like and these types of metal, and an alloy of magnesium and silver.

[0050] It should be noted that an interface between the semi-transparent electrode **211** and the organic layer **107** is a second reflective surface forming the resonant structure.

[0051] The protection layer **109** is a thin-film layer that covers and protects a surface of the transparent electrode **212**. The protection layer **109** is made of a material which is highly transparent for visible light, electrically insulative, and resistant against moisture, oxygen and the like. To be specific, the protection layer **109** can be made of, for example, SiO_x , SiN_x , AlO_x and the like, and formed using sputtering, vapor deposition, a chemical vapor deposition (CVD) method or the like.

[0052] The organic layer **107** is formed by a hole transport layer **201**, an organic light emitting layer **202**, and an electron transport layer **203**, in this order (shown in **FIG. 2**).

[0053] The hole transport layer **201** is a path for holes that are injected from the anodes **106**, and move to the organic light emitting layer **202** in accordance with application of a voltage between the anode **106** and the cathode **108**.

[0054] The hole transport layer **201** is made of a material such as N,N'-Di(naphthalene-1-yl)-N,N'-diphenyl-benzidine: NPB, 4,4',4''-tris(3-methylphenylphenylamino)triphenylamine:MTDATA, and N,N'-diphenyl-N,N'-di(3-methylphenyl)-1,1'biphenyl-4,4'-diamine:TPD.

[0055] The electron transport layer **203** is a path for electrons that are injected from the cathode **108**, and move to the organic light emitting layer **202** in accordance with application of a voltage between the anode **106** and the cathode **108**.

[0056] The electron transport layer **203** is made of a material such as aluminum-quinoline complex (Alq_3) and bis(10-hydroxybenzo[h]quinolinato)beryllium:Bebq₂.

[0057] The organic light emitting layer **202** emits white light in the following manner. Electrons and holes respectively move towards the organic light emitting layer **202**, and are recombined at an interface between the hole transport layer **201** and the organic light emitting layer **202**, at an interface between the electron transport layer **203** and the organic light emitting layer **202**, or within the organic light emitting layer **202**. The recombination generates an energy, which excites electrons of organic molecules in the organic light emitting layer **202**. When the excited electrons are relaxed, white light is emitted.

[0058] Here, to emit white light in this way, the organic light emitting layer **202** is a lamination made up of an organic layer that emits blue light and an organic layer that emits orange light, for example. This is because orange is complementary to blue.

[0059] The organic light emitting layer **202** is made of a material such as aluminum-quinoline complex (Alq_3) and bis(10-hydroxybenzo[h]quinolinato)beryllium:Bebq₂ containing quinaclidon derivative.

[0060] (Design of the Organic EL Panel **100**)

[0061] The organic EL panel **100** relating to the embodiment of the present invention is designed so that a resonant wavelength falls within the blue region of the spectrum, differently from a conventional organic EL panel that is designed without taking a resonant wavelength into account.

[0062] It is generally accepted that a resonant wavelength λ_0 , an optical distance L_0 between reflective surfaces forming a resonant structure, and a phase shift ϕ have a relation defined by the following equation 1. Considering this, to set

the resonant wavelength of the organic light emitting devices **101** within the blue region (400 nm to 520 nm), the value of the resonant wavelength λ_0 is first set within this range. After this, the values of the optical distance L_0 and the phase shift ϕ are determined so as to satisfy the equation 1. Based on the obtained values of the optical distance L_0 and the phase shift ϕ , the organic EL panel **100** is designed.

$$2L_0/\lambda_0 + \phi/(2\pi) = m \quad \text{[EQUATION 1]}$$

[0063] L_0 : optical distance between reflective surfaces forming a resonance structure

[0064] λ_0 : resonant wavelength (nm)

[0065] ϕ : phase shift (Rad)

[0066] m : integer

[0067] The following more specifically describes how to design the organic EL panel **100**. The values of the resonant wavelength λ_0 and the integer m are determined by designers during the designing process. The resonant wavelength λ_0 is set so as to take a value within a wavelength range of the blue region, i.e. no less than 400 nm but no more than 520 nm (preferably no less than 400 nm but no more than 450 nm).

[0068] The integer m is normally set to zero or one.

[0069] The phase shift ϕ indicates a phase shift that is generated when light produced by the organic layer **107** is reflected by the surfaces forming the resonant structure. The phase shift ϕ is determined by materials forming constituents composing the optical path and surface properties of interfaces.

[0070] The value of the phase shift ϕ can be obtained in the following manner.

[0071] First, a refractive index n_1 and an absorption coefficient k of the anode **106** on the TFT substrate **104** are obtained using spectroscopic ellipsometry measurement.

[0072] Subsequently, a refractive index n_2 of the hole transport layer **201**, which is in contact with the anode **106**, is also obtained using spectroscopic ellipsometry measurement.

[0073] Based on the refractive index n_1 , the absorption coefficient k , and the refractive index n_2 , the phase shift ϕ is obtained by means of a method disclosed in a known document (Journal of Applied Physics, Vol. 80 (1996) p 6954). In detail, respective phase shifts of the two interfaces forming the resonant structure are obtained and added together. The sum of the addition is the phase shift ϕ .

[0074] The optical distance L_0 is not a physical distance, but an optically calculated distance between the above-mentioned first and second reflective surfaces. In the present embodiment, the optical distance L_0 is obtained based on a product of a thickness and a refractive index of each of 1) the transparent conductive metal oxide layer forming the anode **106**, 2) the hole transport layer **201**, 3) the organic light emitting layer **202**, and 4) the electron transport layer **203**.

[0075] For example, when the layers 1) to 4) respectively have thicknesses of 1) 800 angstroms, 2) 650 angstroms, 3) 700 angstroms, and 4) 100 angstroms, and have refractive indexes of 1) 2.2, 2) 1.7, 3) 1.7, and 4) 1.7, the optical distance L_0 is 437 nm.

[0076] Here, if the value of $(\phi/2\pi)$ is -0.7 , the resonant wavelength λ_0 is calculated as 515 nm from the equation 1.

[0077] In this case, the resonant wavelength λ_0 is positioned within the blue region. However, to set the resonant wavelength within a more preferable range of no less than 400 nm but no more than 450 nm, the value of the optical distance L_0 , in other words, the thickness and refractive index of each of the layers 1) to 4), may be changed. Alternatively, the value of the phase shift ϕ may be changed. Thus, the obtained resonant wavelength λ_0 can be approximated to a desired wavelength.

[0078] As explained above, the resonant wavelength λ_0 is first set at a certain value, and the values of the optical distance L_0 and the phase shift ϕ are adjusted afterwards.

[0079] Both of the values of the optical distance L_0 and the phase shift ϕ can be adjusted to take any values, as long as the resonant wavelength λ_0 takes a desired value as a result. However, it is more realistic to adjust the value of the optical distance L_0 , as the value of the optical distance L_0 is in the same term as the value of the resonant wavelength λ_0 according to the equation 1.

[0080] (Cause of Color Shifting)

[0081] The following describes a cause of color shifting.

[0082] The relation defined in the equation 1 is true for a resonance light emitting display apparatus, which is represented by the top-emission organic EL panel **100**. Strictly speaking, however, the resonant wavelength λ_0 is a resonant wavelength in a thickness direction of the organic light emitting layer **107**, i.e. in a direction perpendicular to the display unit of the panel **100**.

[0083] As shown in FIG. 3, if the user watches the display unit of the organic EL panel **100** in a direction having an angle of θ degrees with respect to the direction perpendicular to the display unit, the user sees light that runs, in a path at the angle of θ degrees, within the organic layer **107**.

[0084] In the case of this light, the optical distance between the reflective surfaces forming the resonant structure is a distance L_1 . Therefore, a resonant wavelength λ_1 in this direction is defined based on the following equation.

$$2L_1/\lambda_1 + \phi/(2\pi) = m \quad \text{[EQUATION 2]}$$

[0085] λ_1 : resonant wavelength (nm) in the direction having the angle of θ degrees with respect to the direction perpendicular to the display unit

[0086] L_1 : optical distance between the reflective surfaces forming the resonance structure on the optical path at the angle of θ degrees

[0087] ϕ : phase shift (Rad)

[0088] m : integer

[0089] The phase shift ϕ and the integer m take the same values as in the equation 1.

[0090] The following equation shows a relation between the optical distances L_0 and L_1 .

$$L_1 = L_0 / \cos \theta \quad \text{[EQUATION 3]}$$

[0091] The following equation can be obtained based on the relations defined by the equations 1, 2 and 3.

$$2L_0/(\lambda_1 \cos \theta) + \phi / (2\pi) = m \quad \text{[EQUATION 4]}$$

[0092] L_0 : optical distance between the reflective surfaces forming the resonance structure in the direction perpendicular to the display unit

[0093] λ_1 : resonant wavelength (nm) in the direction having the angle of θ degrees with respect to the direction perpendicular to the display unit

[0094] ϕ : phase shift (Rad)

[0095] m : integer

[0096] According to the equations 2, 3 and 4, the larger the angle of the optical path of the received light becomes with respect to the direction perpendicular to the display unit, the shorter wavelength the resonant wavelength is shifted to. Because of this relation, the wavelength of the light that runs through the optical path having an angle with respect to the direction perpendicular to the display unit has its peak in intensity at a shorter wavelength, when compared with the wavelength of the light that runs in the direction perpendicular to the display unit. At the same time, the height of the intensity peak, that is to say, the intensity is different.

[0097] As explained above, the light has a different resonant wavelength depending on an angle of its optical path with respect to the direction perpendicular to the display unit. For better intelligibility, the resonant wavelength in the direction perpendicular to the display unit, i.e. in the thickness direction of the organic layer 107 is hereinafter referred to as an inherent resonant wavelength.

[0098] The following explains a correlation among the wavelength and intensity of the light emitted from the organic layer 107 (hereinafter referred to as a light source wavelength and a light source intensity), a position of the inherent resonant wavelength, and the wavelength and intensity of the light that is actually received by the user (hereinafter referred to as an output wavelength and an output intensity).

[0099] FIGS. 4A, 4B and 4C are used in order to illustrate the above correlation that is observed when the light source wavelength coincides with the inherent resonant wavelength.

[0100] In detail, FIG. 4A illustrates a relation between a wavelength and an intensity of emitted light. FIG. 4B illustrates a position of a resonant wavelength. FIG. 4C illustrates a relation between a wavelength and an intensity of received light, which is observed when the conditions illustrated in FIGS. 4A and 4B are combined.

[0101] As shown in FIGS. 4A to 4C, when the wavelength of the emitted light coincides with the resonant wavelength, the intensity of the received light is increased, to be larger than the intensity of the emitted light.

[0102] On the other hand, FIGS. 4D, 4E and 4F are used in order to illustrate the above correlation that is observed when the light source wavelength does not coincide with the inherent resonant wavelength.

[0103] In detail, FIG. 4D illustrates a relation between a wavelength and an intensity of emitted light. FIG. 4E illustrates a position of a resonant wavelength. FIG. 4F

illustrates a relation between a wavelength and an intensity of received light, which is observed when the conditions illustrated in FIGS. 4D and 4E are combined.

[0104] In this case, the intensity of the received light is lower than the intensity of the emitted light, and the peak in intensity of the received light is shifted to be closer to the resonant wavelength. Here, the difference in intensity between the emitted light and the received light is smaller, when compared with a case where the wavelength of the emitted light coincides with the resonant wavelength.

[0105] (Motive to Set the Inherent Resonant Wavelength)

[0106] Such correlations led the inventors of the present invention to discover that color shifting, which occurs when the user watches the display unit of the panel 100 in the direction having an angle with respect to the direction perpendicular to the display unit, can be limited, by setting the inherent resonant wavelength of the organic light emitting devices 101 within the blue region of the spectrum.

[0107] This discovery is described in detail in the following.

[0108] FIG. 5A illustrates a transition of the wavelength of the light received by the user, when the angle of the direction in which the user watches the display unit gradually increases with respect to the direction perpendicular to the display unit.

[0109] The light emitted from the organic layer 107 is white light composed of three primary colors, that is to say, including red light, green light, and blue light.

[0110] FIG. 5A also shows optical transmission characteristics of the color filters 112r, 112g and 112b, each of which transmits a corresponding one of red light, green light and blue light composing the white light.

[0111] Conventionally, an inherent resonant wavelength of a resonance organic EL panel is not set at a particular value. However, the inherent resonant wavelength of the organic EL panel 100 relating to the present embodiment is set within the blue region, more specifically, in the vicinity of the ultraviolet region, as shown in FIG. 5A.

[0112] Among the red, green and blue light included in the white light, wavelengths of the green light and red light are positioned further away from the inherent resonant wavelength, than that of the blue light is. When the user watches the display unit in the direction having an angle with respect to the direction perpendicular to the display unit, the intensity peaks of the green light and red light in the light received by the user are shifted to a shorter wavelength, and are lowered. The degree of these changes is smaller, when compared with the intensity peak of the blue light, which is positioned closer to the inherent resonant wavelength. Accordingly, the difference in the output intensity, which is caused by the increase in the angle, is moderate as for the green light and red light.

[0113] On the other hand, the wavelength of the blue light is positioned closer to the inherent resonant wavelength. When the user watches the display unit in the direction having an angle with respect to the direction perpendicular to the display unit, the intensity peak of the blue light in the light received by the user is shifted to a shorter wavelength, and is raised. The degree of these changes is more signifi-

cant, when compared with the intensity peaks of the green light and red light. However, as the wavelength of the blue light in the received light is shifted to a shorter wavelength, part of the intensity-wavelength distribution of the blue light is included in the ultraviolet region which indicates less visibility. Therefore, the difference in the output intensity, which is caused by the increase in the angle, appears to be moderate as for the blue light.

[0114] For these reasons, even when the user watches the display unit in the direction having an angle with respect to the direction perpendicular to the display unit, a change in luminance is moderate for the blue light, green light and red light in the received light. As a consequence, only slight color shifting occurs.

[0115] Here, it is assumed that the inherent resonant wavelength is positioned in a region other than the blue region, for example, the green region. As shown in FIG. 5B, as the angle of the direction in which the user watches the display unit of the panel 100 increases with respect to the direction perpendicular to the display unit, the output intensity of the green light significantly changes, the output intensity of the blue light increases, and the output intensity of the red light lowers. These changes enormously deteriorate the balance of the three primary colors composing the white light, thereby causing color shifting.

[0116] Furthermore, it is assumed that the inherent resonant wavelength is positioned in the red region (not illustrated in FIG. 5). As the angle of the direction in which the user watches the display unit increases with respect to the direction perpendicular to the display unit, the output intensity of the red light significantly changes, the output intensity of the blue light increases, and the output intensity of the green light also increases. These changes cause color shifting.

[0117] For the purpose of convenience, the above description of the present embodiment is made with focus on one inherent resonant wavelength. However, there are actually a plurality of inherent resonant wavelengths at certain intervals.

[0118] Here, it is possible to set an inherent resonant wavelength A in the infrared or ultraviolet region. In this case, however, an inherent resonant wavelength B or C adjacent to the inherent resonant wavelength A is thought to be positioned in the visible region. Therefore, the above description does not particularly make reference to a case where the inherent resonant wavelength is positioned in the infrared or ultraviolet region.

[0119] (Confirmation of Effects)

[0120] To confirm the effect that color shifting can be moderated if the inherent resonant wavelength is positioned in the blue region, the inventors of the present invention performed simulations. In detail, they observed changes in position, on a chromaticity diagram, of light which has passed through each of the color filters 112r, 112g and 112b, by varying the position of the inherent resonant wavelength as stated in the following.

[0121] <Setting Inherent Resonant Wavelength>

[0122] The inherent resonant wavelength is assumed to be 610 nm (the red region), 550 nm (the green region), and 515 nm (the blue region).

[0123] <Angle of Direction in which User Watches Display Unit with Respect to Direction Perpendicular to Display Unit>

[0124] The user is assumed to watch the display unit in the direction perpendicular to the display unit, in the direction at an angle of 30 degrees with respect to the perpendicular direction, and in the direction at an angle of 45 degrees with respect to the perpendicular direction.

[0125] <Results of Simulations>

[0126] FIG. 6 shows positions, on the chromaticity diagram, of the white light that is emitted from the organic layer 107 and received by the user after passing through the green color filters 112g. The results are obtained by simulations where the angle between the direction perpendicular to the display unit and the direction in which the user watches the display unit is varied and the inherent resonant wavelength is varied.

[0127] As shown in FIG. 6, when the inherent resonant wavelength is 515 nm (the blue region), a smaller change in position on the chromaticity diagram is observed in accordance with the change in the angle, in comparison with a case where the inherent resonant wavelength is set to the different values.

[0128] This means that, when the inherent resonant wavelength is 515 nm (the blue region), the change in output wavelength of the green light is limited.

[0129] FIG. 7 shows positions, on the chromaticity diagram, of the white light that is emitted from the organic layer 107 and received by the user after passing through the blue color filters 112b. The results are obtained by simulations where the angle between the direction perpendicular to the display unit and the direction in which the user watches the display unit is varied and the inherent resonant wavelength is varied.

[0130] As shown in FIG. 7, when the inherent resonant wavelength is 515 nm (the blue region), a smaller change in position on the chromaticity diagram is observed in accordance with the change in the angle, in comparison with a case where the inherent resonant wavelength is set to the different values.

[0131] This means that, when the inherent resonant wavelength is 515 nm (the blue region), the change in output wavelength of the blue light is limited.

[0132] FIG. 8 shows positions, on the chromaticity diagram, of the white light that is emitted from the organic layer 107 and received by the user after passing through the red color filters 112r. The results are obtained by simulations where the angle between the direction perpendicular to the display unit and the direction in which the user watches the display unit is varied and the inherent resonant wavelength is varied.

[0133] As shown in FIG. 8, irrespective of whether the inherent resonant wavelength is 610 nm (the red region), 550 nm (the green region), and 515 nm (the blue region), only a small change in position on the chromaticity diagram is observed in accordance with the change in the angle.

[0134] This means that, irrespective of the positions of the inherent resonant wavelength, the change in output wavelength of the red light is limited.

[0135] Although the present invention has been fully described by way of examples with reference to the accompanying drawings, it is to be noted that various changes and modification will be apparent to those skilled in the art. Therefore, unless otherwise such changes and modifications depart from the scope of the present invention, they should be construed as being included therein.

What is claimed is:

1. A light emitting display apparatus that achieves color display by using white light as a light source, comprising:

a plurality of organic light emitting devices each of which includes an organic light emitting layer that emits the white light, the organic light emitting device being configured so that a resonant wavelength in a thickness direction of the organic light emitting layer is positioned in the blue region of the spectrum; and

a plurality of wavelength selection units each of which is provided on a path of the emission of the white light, the wavelength selection unit transmitting light of a particular wavelength included in the white light.

2. The light emitting display apparatus of claim 1, wherein the blue region of the spectrum indicates a wavelength range of 400 nm to 520 nm, inclusive.

3. The light emitting display apparatus of claim 2, wherein the resonant wavelength falls within a range of 400 nm to 450 nm, inclusive.

4. The light emitting display apparatus of one of claims 1 to 3, wherein

the wavelength selection unit is a color filter that transmits light of a corresponding one of three primary colors.

5. The light emitting display apparatus of one of claims 1 to 3, wherein

at least one of a thickness of the organic light emitting layer, a refractive index of the organic light emitting layer, and a phase shift ϕ of the organic light emitting layer is adjusted so that the resonant wavelength in the thickness direction of the organic light emitting layer is positioned in the blue region of the spectrum.

* * * * *

| | | | |
|----------------|--|---------|------------|
| 专利名称(译) | 具有轻微色移的发光显示装置 | | |
| 公开(公告)号 | US20050212414A1 | 公开(公告)日 | 2005-09-29 |
| 申请号 | US11/079528 | 申请日 | 2005-03-15 |
| [标]申请(专利权)人(译) | MATSUSUE NORIYUKI 二宫国本 | | |
| 申请(专利权)人(译) | MATSUSUE NORIYUKI 二宫国本 | | |
| 当前申请(专利权)人(译) | SANYO ELECTRIC CO. , LTD. | | |
| [标]发明人 | MATSUSUE NORIYUKI NINOMIYA KUNIMOTO | | |
| 发明人 | MATSUSUE, NORIYUKI NINOMIYA, KUNIMOTO | | |
| IPC分类号 | H05B33/24 H01J1/62 H01J63/04 H01L27/32 H01L51/50 H01L51/52 H05B33/02 H05B33/10 H05B33/12 H05B33/14 H05B33/22 | | |
| CPC分类号 | H01L27/322 H01L51/5036 H01L2251/5315 H01L51/5265 H01L51/5237 H01L51/524 H01L51/5253 | | |
| 优先权 | 2004089131 2004-03-25 JP | | |
| 其他公开文献 | US7508005 | | |
| 外部链接 | Espacenet USPTO | | |

摘要(译)

通过使用白光作为光源实现彩色显示的发光显示装置包括多个有机发光装置，每个有机发光装置包括发射白光的有机发光层。有机发光器件被配置为使得有机发光层的厚度方向上的共振波长位于光谱的蓝色区域中。发光显示装置还包括多个波长选择单元，每个波长选择单元设置在白光发射的路径上。波长选择单元透射包括在白光中的特定波长的光。

